

Metro 3kW or 4kW Wetback Installation Instructions

CAUTION! Important Information

- Wetbacks must be connected with water before operating the fire. Water must always be available to the wetback while the fire is in operation.
- Wetback systems are not suitable for use in locations where the water supply has lime content. Lime build up inside the coil will eventually block the coil causing the wetback to fail.
- Rainwater collection tanks installed lower than the wetback that use a water pump to supply the home, can cause problems if the pump is not operational. In these situations either the type of wetback or a roof header tank should be considered.

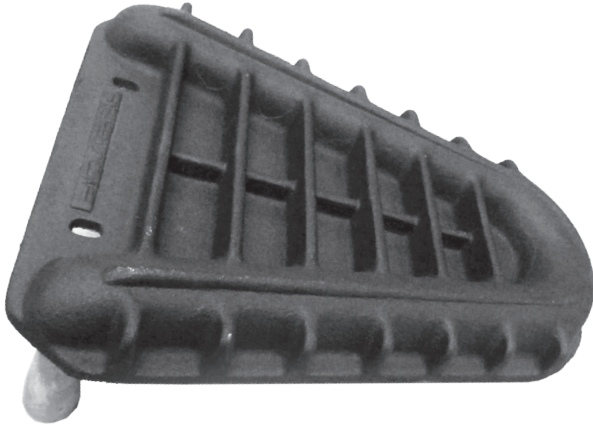

METRO 3kW or 4kW WETBACK

WARNING! Important Information

- Do not connect to an unvented hot water system.
- Install in accordance with AS 3500.4.1 or NZS 4603 and the appropriate requirements of the relevant building code or codes.

Suitable for installation into the following models:

- LTD Wee Rad
- LTD Xtreme Rad
- LTD Mega Rad
- Xtreme Ped
- Xtreme Rad Base
- Mega Rad
- LTD Wee Rad Base
- LTD Xtreme Rad Base
- LTD Trend Insert
- Xtreme Rad
- Xtreme Rad Woody

LTD Metro's can be fitted with an optional 3kW or 4kW wetback, designed to give maximum output with minimal effect on the operation of the fire. Only Pioneer's cast jacket wetback system should be fitted to a Metro. Alternative wetbacks will void the Metro's emission approvals and may seriously affect the performance of the appliance and void the owner's warranty.

The clean air approved Mega Rad, Xtreme Rad, Xtreme Rad Base, Xtreme Rad Woody & Xtreme Ped models are only suitable for installation of the 3kW wetback.

Note: Wetback systems are not suitable for use in locations where the water supply has lime content, lime build up inside the coil will eventually block the coil causing the wetback to fail.

3kW or 4kW Wetback

The 3kW wetback is usually adequate for most homes; however, if your hot water use is considerable the 4kW would be a preferable option in 'LTD' Metro's only. Other considerations are:

Distance from the Metro to the storage cylinder will affect the amount of hot water produced. If it is more than 2 metres away the 4kW is usually preferable.

Your climate and the manner in which you will "fire" your Metro are the most relevant factors in choosing the correct output wetback. If you are in a moderate climate or have a modern well-insulated home you are likely to be running your Metro on lower output settings, in which case the 4kW should be used. If however you live in a cold climate, or have an older, cold or large home you are more likely to be "firing" your Metro on a higher burn rate, in which case the 3kW would be better suited.

Both 3kW and 4kW wetback options are fitted to the inside rear of the firebox, with the connection pipe heights illustrated and detailed on the opposite page. Please note:-

- Wetback connections for the Metro models listed are 140mm left of the flue centre, facing the Metro/wall; the return pipe connection is directly above the inlet connection.
- It is recommended the return pipe has a minimum rise of 1 in 12; performance will reduce as the distance to the storage cylinder increases.

Fitting the wetback to a freestanding model:

1. Remove the rear panel of the Metro by removing the four pozi drive screws. Remove the two pre-punched knockouts from this panel.
2. Two further knockouts will be visible on the inner rear heatshield, remove these also. Once these are removed 6mm nuts will be visible through the knockout holes.
3. Open the Metro's door and locate two bolts securing the pressed washers which are visible on the left hand side of the firebox for both inlet and outlet connection points.
4. A further three bolt heads will also be visible on the inside rear wall of the firebox; these are threaded into the 6mm thick firebox. Remove all three.
5. Using the tube of sealant supplied with the wetback, apply a liberal bead of sealant around both connection holes on the inside of the firebox. On the rear of the wetback casting apply the remaining contents of the tube equally around both connection pipes and also the outer circumference

Metro 3kW or 4kW Wetback Installation Instructions

of the wetback which will face the inside rear wall of the firebox. This will completely seal the wetback to the inside rear wall of the fire on installation.

Ensure there is no gap between pipe and rear wall access holes. This cement must fully cure before appliance use.

- Fit the wetback into the firebox and carefully pass the connection pipes through the holes in the rear of the firebox. Securely attach the wetback using the three bolts previously removed from the rear face of the firebox, fitting them through the slots provided in the wetback's jacket.
- The wetback is now ready for connection to the storage cylinder by a registered plumber.

Fitting the wetback to the LTD Trend Insert:

- Remove the brick from the inside of the firebox from the side the wetback is to be fitted too.

- Expose the holes in the firebox through which the connection pipes will pass.

The LTD Insert has a 3mm pressed washer covering these two openings and two 6mm bolts which are fitted inside the firebox near the connection holes, remove these also.

- Using a hole saw or snips, prepare the cabinet for the connection pipes. Note, these holes should be a neat fit or have any excess gap covered or filled with high temperature insulation.
- Using the tube of sealant supplied with the wetback, apply a liberal bead of sealant around both connection holes on the inside of the firebox. On the rear of the wetback casting apply the remaining contents of the tube equally around both connection pipes and also the outer circumference of the wetback which will face the inside rear wall of the firebox. This will completely seal the wetback to the inside rear wall of the fire on installation.

Ensure there is no gap between pipe and rear wall access holes. This cement must fully cure before appliance use.

- Fit the wetback into the firebox and position the connection pipes through the connection holes in the firebox.
- Fit two bolts through the slots provided in the wetback, align the wetback so its front edge is parallel to the door opening & secure the bolts. The wetback is ready for connection to the storage cylinder by a registered plumber.

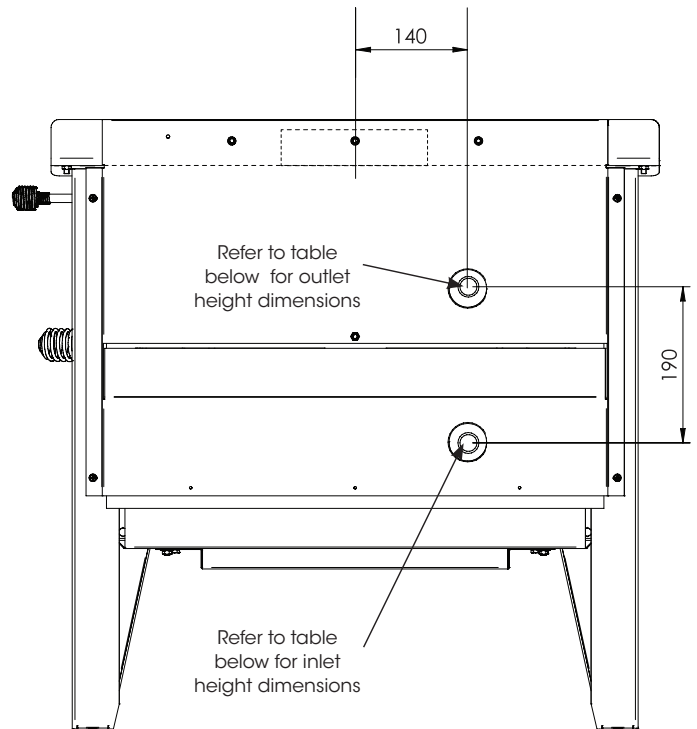

Wetback installation into a freestanding model

Metro wetback connection heights (Measurements shown are in mm)

Model	N	O
LTD Wee Rad	295	485
LTD Wee Rad Base	300	490
LTD Xtreme Rad	350	540
LTD Xtreme Rad Base	350	540
LTD Mega Rad	300	490
LTD Trend Insert	170	360
Xtreme Rad	312	502
Xtreme Rad Base	312	502
Xtreme Rad Woody	382	572
Xtreme Ped	312	502
Mega Rad	300	490

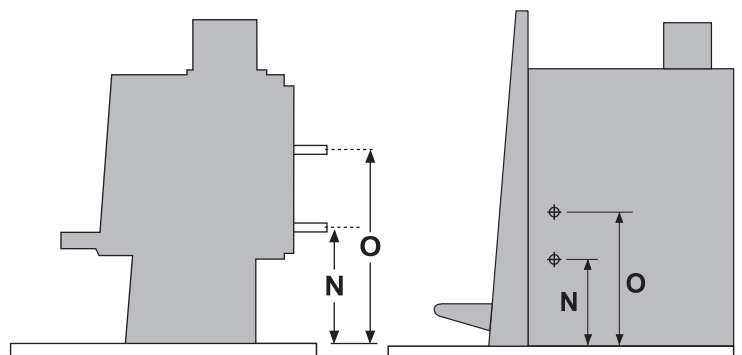

Note: Freestanding wetback connections are 140mm left of the flue centre, facing the Metro/wall.

LTD Trend Insert wetback connections. Wetback can be fitted on either left or right hand side of the firebox (internally).