

ECO Flue System Installation Manual

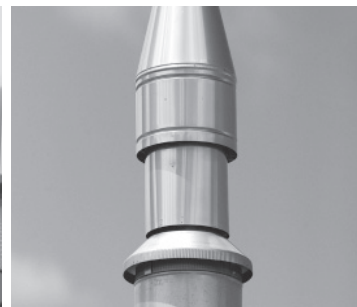
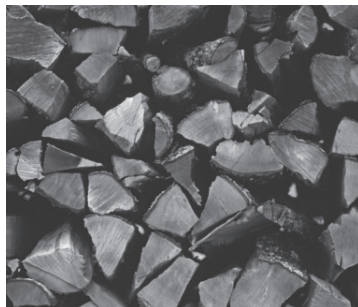

metrofires

ECO Flue Systems

Freestanding Flue Systems

ECO Flue System Installation Options.....	2
ECO Base Flue System & ECO Option Kits....	3
ECO Base Flue System Kit Installation	4-5
ECO Option Kit Installation.....	5

Insert Flue Systems

ECO Insert Flue System Kit Installation	6-7
ECO Flue System Minimum Heights	8

⚠ WARNING! Important Information

- Metro ECO Base Flue Systems must be installed to allow unrestricted air supply from either the ceiling cavity for an eco base kit, or above the roof line if the base & option kits are both installed. Please read these and familiarise yourself with the installation options and various components of the ECO Flue Systems
- The ECO Base Flue System must be installed into a “vented” flat ceiling cavity, or have an ECO Option Kit added to the flue system to provide an external air supply
- The ECO Flue Systems shall be installed in accordance with AS/NZS2918:2001 and the appropriate requirements of the relevant building codes
- Any modification to this flue system that has not been approved in writing by the testing authority is considered to be in breach of all approvals granted

⚠ CAUTION! Important Information

- Mixing of flue system components from different sources or modifying the dimensional specification or components may result in hazardous conditions. Where such action is considered, the manufacturer should be consulted.
- Prior to installing the assembled flue pipe into the masonry chimney cavity, take careful note to ensure there are no overhead power lines in close proximity.

Installation Options ECO Flue Systems

Detailed below are the more common installation methods for installing Metro ECO Flue Systems. To ensure a safe and efficient installation, this flue system must be installed as detailed below by either a registered installer, or someone competent in installing solid fuel appliances.

Single Storey Installations

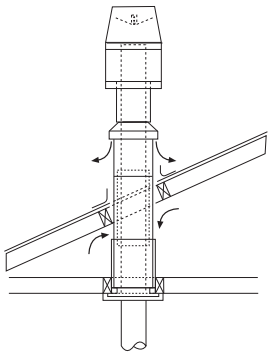

FLAT CAVITY CEILING

ECO Base Flue System only required as air is drawn into the flue system direct from the ceiling cavity.

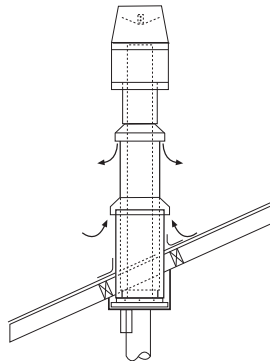

SLOPING CEILING

Both the ECO Base Flue System and Option kit are required to enable air to be drawn from outside the home.

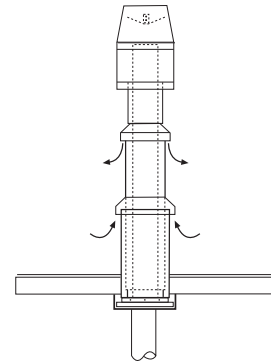

FLAT CEILING/ROOF

Requires both ECO Base Flue System and Option kit as per sloping ceiling unless a vented ceiling cavity exists.

Two Storey Installations

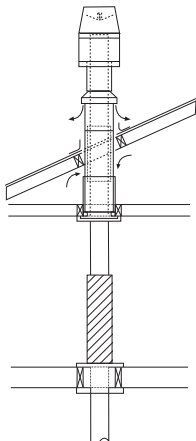

2ND FLOOR EXPOSED FLUEPIPE

Requires an ECO Base Flue System only with additional lengths of Fluepipe, a floor penetration kit, 1 x 1200mm long mesh/screen.

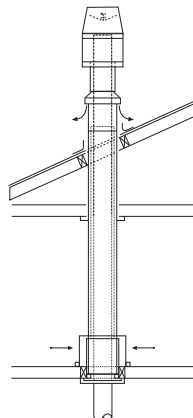

2ND FLOOR ENCLOSED FLUEPIPE

Requires an ECO Base Flue System only with additional lengths of Fluepipe, 200mm & 250mm inner/outer combination liners, an ECO 2nd floor vent cover and an additional ceiling plate with a 250mm diameter hole.

Component Checklist ECO Base Flue System Kit & ECO Option Kit

Metro offer both the ECO Base Flue System, which is designed to be installed on its own and the ECO Option kit which is designed to be installed in conjunction with the ECO Base Flue System. The specific application for each of these two options is detailed below.

Metro ECO Base Flue System Kit - Metro ECO Base Flue Systems are designed for installation into a building that has a "ceiling cavity" with unrestricted air supply as is the case with

conventional homes. A vented ceiling cavity is required as the base kit draws its cooling air from the ceiling cavity.

Metro ECO Option kits - The Metro ECO Option kit is designed to be "added to" the Metro ECO Base Flue System for installations that do not have a vented ceiling cavity and require the flue systems cooling air to be drawn in from above the roofline (outside the building).

ECO BASE FLUE SYSTEM ASSEMBLED

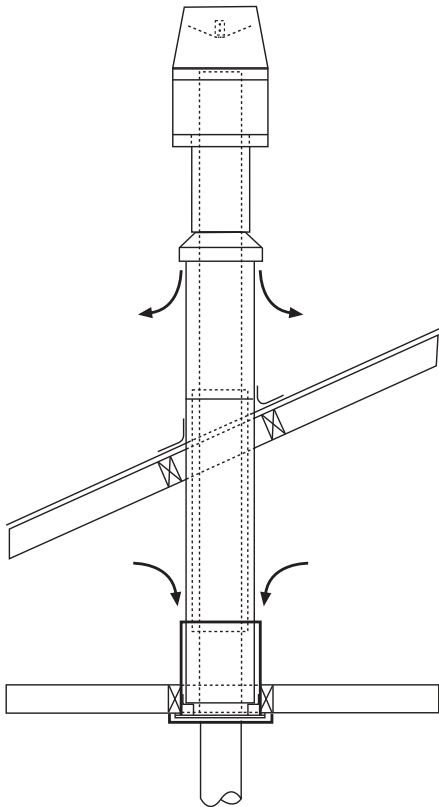

ECO BASE FLUE SYSTEM COMPONENTS

- (A) 1 x Stainless steel weather butterfly
- (B) 1 x Stainless steel ECO cowl housing
- (C) 1 x 225mm x 200mm diameter stainless steel outer casing extension
- (D) 1 x 480mm long stainless steel flue pipe extension with flashing cone
- (E) 1 x 1200mm x 150mm diameter stainless steel flue pipe
- (F) 1 x 1200mm x 250mm diameter galvanised outer casing with 750mm long slip section
- (G) 1 x 800mm x 200mm diameter galvanised inner casing
- (H) 1 x Galvanised mounting plate with brackets and 300mm long x 300mm diameter casing attached
- (I) 1 x insulation gasket
- (J) 1 x black clip-on ceiling plate
- (K) 2 x 1200mm lengths of 150mm diameter stainless steel flue pipe painted metallic black
- (+) - 1 x Plastic bag of assembly bolts

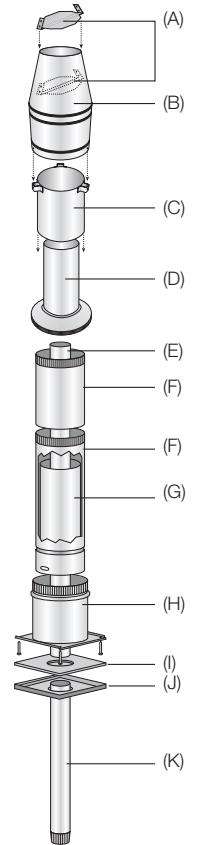

ECO BASE FLUE SYSTEM & ECO OPTION KIT ASSEMBLED

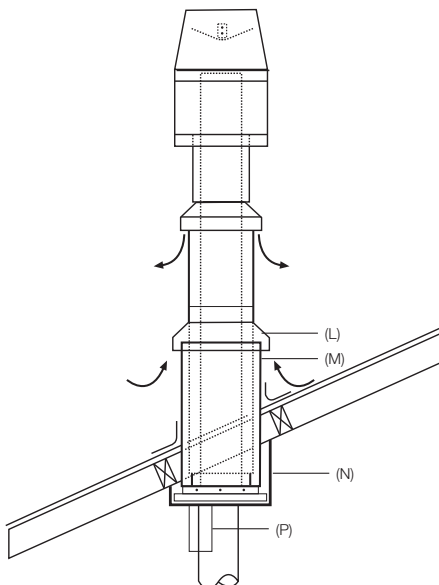

ECO OPTION KIT COMPONENTS

- (L) External intake flashing cone
- (M) 300mm diameter outer liner extension
- (N) Drop box infill panel
- (O) Drop box edge covers
- (P) Ceiling plate mounted heat shield

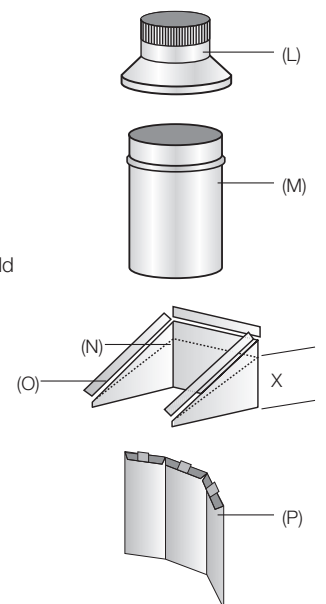

Installation Instructions ECO Base Flue System

Having positioned the wood fire in the desired location, check to ensure the wood fire and floor protector have adequate clearances/projections, and that the flue system is clear of ceiling joists, trusses etc. (refer to the wood fire Installation and Operation Manual).

Note: ECO Flue Systems use stainless steel brackets enabling movement due to expansion, while centralising flue pipes and casings. These brackets may require resetting after transport, if they are too loose or tight during assembly;

1. At a point directly above the wood fires flue centre, cut a 300mm square hole through the ceiling and a 250mm diameter hole through the outer roof lining providing it is non combustible (iron, tiles etc) otherwise cut a 250mm square hole through the roof lining. "Trim out" the top face of the ceiling using timber nog's creating a square aperture measuring 300mm internally.

Note: Certain flashing manufacturers detail specific size and shape of the aperture to be cut for their flashing, which must be adhered to.

2. Fit mounting plate (H) into the ceiling by sliding the 300mm diameter casing attached to the mounting plate up into the ceiling until the two upturned edges rest against the under side of the ceiling. Square the mounting plate to the wall and secure it in location with the 4 coach bolts supplied, into the nog's just fitted. To further improve the rigidity of the installation, nail through the 300mm diameter casing at 4 points into the timber nog's.

3. Moving onto the roof with the 1200mm x 250mm diameter galvanised outer casing (F) with 750mm long slip section fitted, lower the slotted end of this casing (F) into the roof cavity until it locates inside the brackets on the top face of the mounting plate. Return back into the room and using the 2 x 6mm bolts and washers supplied, securely bolt the base of the 250mm diameter outer casing to the rivet nuts pre-fitted into the mounting plate brackets.

Note: As there are two bolts, the outer casing can be rotated 180 degrees. Ensure the lock-form seam is rotated so the seam is sheltered as much as possible from the prevailing weather direction.

4. Return back onto the roof and using a suitable flashing, weather proof the joint where the 250mm diameter outer casing penetrates the roof. Ensure the flashing used is compatible with the roofing material, and if fitting instructions are supplied with the flashing, these must be adhered to. Prior to fitting the flashing, by fitting brackets securing the outer casing (F) to the roof material will further improve rigidity of the installation.

5. While on the roof fit the 800mm x 200mm diameter galvanised inner casing (G).

Note: This inner casing has a top and bottom, the bottom end has both internal and external brackets while the top end has external only. Fit the bottom end of this inner casing (G) down into the 250mm diameter outer casing (F) until the casings lower external brackets locate on the internal swadge of the outer casing.

WARNING! Important Information

- **If there is timber or combustibles within 25mm of the outer casing (f) in a zone "above the top end of the inner casing (g) and below the roof line" additional 200mm inner casing must be fitted.**

ECO BASE FLUE SYSTEM KIT COMPONENTS

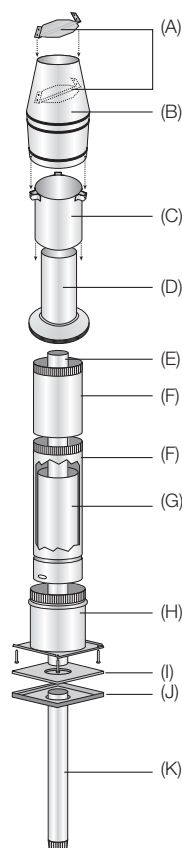

ECO OPTION KIT COMPONENTS

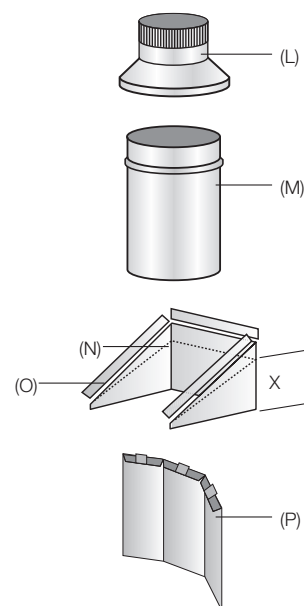

6. Moving back into the home, remove the plastic film from the ceiling plate (J) and place it black side down over the flue outlet of the woodfire. Using a high temperature black aerosol, spray around the hole in the centre of the white insulation gasket, and when dry lay this centrally on the ceiling plate.
7. Unwrap the two painted flue pipes (K) taking care not to mark the painted surface (use a metallic black Stovebright aerosol for touch ups) and proceed to assemble the three fluepipe sections as described below;
 - Smear an adequate amount of Pioneer fire cement inside the "top/un-crimped" end of both painted flue pipes (K).
 - Taking the unpainted stainless steel fluepipe (E) insert its top "un-crimped" end up through the mounting plate (H) and up into the casings until its bottom "crimped" end is 1250mm above the top of the wood fire.
 - Take one of the two painted stainless steel flue pipes (K) and fit its lower "crimped" end into the Metro wood fires flue outlet. Now lower the unpainted stainless steel flue (E) which is protruding down from the mounting plate so that it fully connects into the lower painted flue pipe (K). Ensure these two flue pipe sections are firmly connected and aligned, then secure with three stainless steel or monel rivets spaced equally around the joint.
 - Lift the two assembled flue pipe sections so the bottom of the lower section is 1250mm above the top of the wood fire, and repeat the above procedure to fit the remaining painted flue pipe (K).

Installation Instructions ECO Base Flue System - continued

- With all three fluepipe sections securely joined, lift this three section assembly out of the wood fires flue outlet, then move it slightly off centre and lower the flue pipe assembly “on top” of the wood fires flue outlet. Smear an adequate amount of Pioneer fire cement inside the wood fires flue outlet (move the flue pipe assembly as required to ensure the entire flue outlet is coated in fire cement) then lower the flue pipe back into the wood fires flue outlet, with the vertical flue seam facing the rear.
- 8. Taking the ceiling plate (J) with insulation gasket (I) fitted which are laying on top of the wood fire, with the flue pipe passing through them. Carefully lift them up the flue pipe trying not to mark the painted flue, and clip the ceiling plate onto the mounting plate.
- 9. While still on the ground, assemble the ECO vertical discharge cowl as follows;
 - Take the stainless steel weather butterfly (A) so the angled sections are facing up and fold “up” both arms at the slot provided to just over 90 degrees as shown.
 - With both arms and angled sections of the stainless steel weather butterfly (A) facing up, fit it into the stainless steel cowl housing (B), and secure in position through the holes provided with stainless steel rivets.

Note: Once fitted the weather butterfly will be slightly angled within the cowl housing.
- Now fit the base of the cowl housing (B) over the brackets of the outer casing extension (C) ensuring the 3 x prepunched holes punched in its lower skirt align centrally over the 3 brackets attached to the casing extension as illustrated. Push the cowl housing down fully until its internal swage rests on the casing extension brackets (the brackets should be “just but fully” inside the base of the cowl housing). Drill through the 3 pre-punched holes in the cowl housing through the 3 brackets and secure with stainless steel rivets.
- 10. Making your way back onto the roof, slide the 750mm long slip section of the outer casing (F) until the top of this slip section is “level” (+ or –10mm) with the top of the 150mm stainless steel flue pipe, then secure this slip section of the outer casing with rivets.
- 11. Fit the 480mm long flue pipe extension/flashing cone (D), with the flashing cone at the bottom, fit its short flue section inside the top of the already installed 150mm diameter flue pipe. Ensure the 3 brackets extended below the flashing cone fit “outside” the outer casing slip section. Drill through the pre-punched hole in all 3 brackets into the outer casing slip and secure with rivets.
- 12. Taking the “removable section of the ECO cowl”, position it over the top of the stainless steel flue pipe extension, and slide it down fully. This removable section does not require riveting and therefore enables easy removal for future flue cleaning.

Installation Instructions ECO Option Kit

Dependant on whether you are installing into a flat roof/ ceiling or sloping ceiling situation as detailed on page 2, will determine if you require all the components of the ECO Option kit, if installing into a flat ceiling/roof you will not require the drop box or drop box edge covers.

Note: The 300mm diameter outer liner extension (M) supplied with the ECO Option kit is supplied at the maximum length it has been tested, and must not be extended.

- 13. Slip the 300mm outer extension liner supplied with the ECO Option kit over the 300mm outer liner “stub” attached to the mounting plate (H) supplied with the base kit. Permanently secure these two components together by drilling 4 evenly spaced holes around the circumference and rivet with stainless steel rivets.
- 14. Proceed as detailed in item's 1 and 2 of the ECO Base Flue System kit's installation sheet and note:
 - If the ceiling is angled, it is critical that the mounting plate is correctly positioned so the drop box in-fill panel can be fitted. Ensure the two “upturned folds” on the mounting plate are aligned parallel to the roof joists, i.e pointing towards the apex.
 - If the ceiling is angled, you will only be able to use two of the securing holes provided in the mounting plate. To give additional support to the installation nail through the 300mm diameter outer liner into the timber framing, access is through the 200mm hole in the base of the mounting plate.
- 15. Proceed as detailed in item 3 of the ECO Base Flue System Kit installation instructions.
- 16. Fit the external “intake” flashing cone supplied with the option kit as illustrated, and secure it to the top of the 300mm diameter extension liner through the 4 x brackets which protrude below the base of the external “intake” flashing cone.
- 17. Proceed as detailed in items 4 through 9 of the ECO Base Flue System Kit installation instructions.
- 18. Measure dimension “X” as shown opposite and transfer this measurement to the drop box in-fill panel as shown.
 - Cut the in-fill panel to the correct size and fit the 3 x edge covers.

Note the side edge covers will require trimming on the ends to suit the angle of the ceiling.
 - Secure the in-fill panel in position by fitting three rivets to each side through the holes provided.
- 19. Back in the room, lift the ceiling plate then attach the “ceiling plate mounted heat shield” to the lower face of the ceiling plate so that it acts as a deflector shield between the flue pipe and the lower side of the ceiling (refer assembled diagram on page 3). This heat shield has 3 tabs on its top face enabling it to be “clipped” into the 160mm diameter hole in the ceiling plate. Attach the ceiling plate by clipping it onto the mount plate and the installation is now complete.

Component Checklist ECO Insert Flue System Kit

Please read these instructions fully prior to installation of the Insert Flue System and familiarise yourself with all the various components as illustrated right and listed below.

Note: Rivets and fire cement are not included as they are supplied by the installer.

ECO INSERT FLUE SYSTEM KIT COMPONENTS

- (A) 1 x Stainless steel weather butterfly
- (B) 1 x Stainless steel ECO cowl housing
- (C) 1 x 225mm x 200mm diameter stainless steel outer casing extension
- (D) 1 x 480mm long stainless steel flue pipe extension with flashing cone
- (E) 3 x 1200mm x 150mm diameter stainless steel flue pipe
- (F) 1 x 600mm x 250mm diameter galvanised outer casing

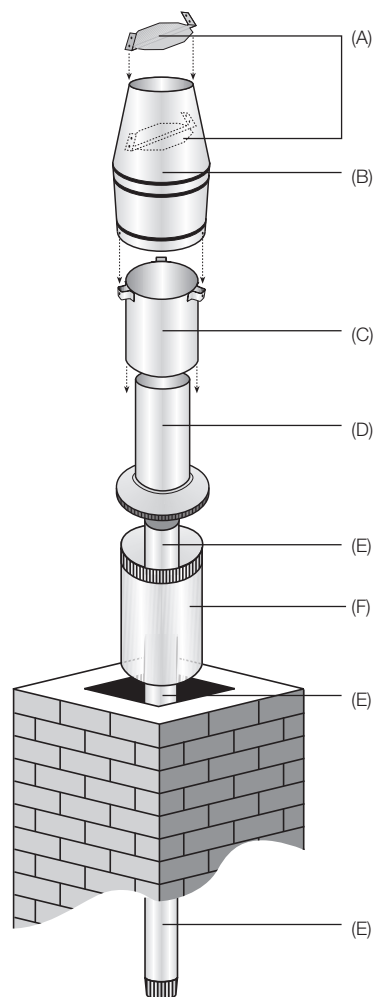

Installation Instructions ECO Insert Flue System

This flue system has been manufactured and complies with AS/NZS2918:2001. To ensure a safe and efficient installation, this flue system must be installed as detailed below by either a registered installer, or someone competent in installing solid fuel appliances.

1. Check the masonry chimney for structural soundness and make any repairs that are necessary.

Note: Most councils require the masonry chimney to be inspected prior to installation. The masonry chimney cavity must also be swept prior to installation.

2. Once the fireplace insert has been installed correctly as per the manufacturers instructions, look directly down the chimney to ensure the wood fire flue spigot is in line with the masonry chimney. (A torch will be required).
3. If you cannot see the flue spigot, a fluepipe offset will be required. If so, install the fluepipe offset so the top of it can be clearly seen from the top of the masonry chimney.
4. If an offset is required, an adjustable telescopic type is recommended. Measure the amount of offset required and adjust the telescopic offset to suit, after smearing an adequate amount of Pioneer fire cement onto the slip section of the offset to ensure a good seal, then rivet the offset in three locations around its circumference. (If the offset is used in its fully compressed form, it will be necessary to modify the end of the female slip section otherwise it will restrict the internal diameter) Apply a liberal amount of Pioneer fire cement into the flue outlet of the fireplace insert, and fit the lower crimped end of the offset into position inside the flue outlet, and bolt into position.

Note: In some installations where it is not possible to fit offsets or rigid fluepipe due to the shape of the masonry chimney cavity, "Flexi flue" may be used.

5. Secure the fluepipes together and ensure the flue seams are in line. Fluepipe joints must be fully compressed with a considerable amount of fire cement to ensure a good seal, and then riveted together at 3 even points around the flue join. Prior to installing the assembled fluepipe into the masonry chimney cavity, take careful note to ensure there are no overhead power lines in close proximity.
6. Lower the fluepipe into the masonry chimney, with the crimped end fitting into the fireplace insert flue outlet/offset, and securely attach with three rivets. (offset/bend must be riveted to the fluepipe) For installations where extra lengths of fluepipe are required, or when the weather is poor, it will be easier to assemble the fluepipe lengths as they are lowered into the masonry chimney.

7. Secure the outer casing to the masonry chimney with suitable fasteners and weatherproof/seal to the masonry chimney top with mortar or silicone. Note: The top of the outer casing must be "level" (+ or - 10mm) with the top of the 150mm stainless steel fluepipe. An optional masonry chimney flashing plate is available if required.

8. Assemble the ECO vertical discharge cowl as follows;

- Take the stainless steel weather butterfly (A) so the angled sections are facing up and fold "up" both arms at the slot provided to just over 90 degrees as shown.
- With both arms and angled sections of the stainless steel weather butterfly (A) facing up, fit it into the stainless steel cowl housing (B), and secure in position through the holes provided with stainless steel rivets.

Note: Once fitted the weather butterfly will be slightly angled within the cowl housing.

- Now fit the base of the cowl housing (B) over the brackets of the outer casing extension (C) ensuring the 3 x prepunched holes punched in its lower skirt align centrally over the 3 brackets attached to the casing extension as illustrated. Push the cowl housing down fully until its internal swage rests on the casing extension brackets (the brackets should be "just but fully" inside the base of the cowl housing). Drill through the 3 pre-punched holes in the cowl housing through the 3 brackets and secure with stainless steel rivets.

The removable section of the ECO cowl is now fully assembled.

9. Making your way back onto the roof, fit the 480mm long fluepipe extension/flashing cone (D), with the flashing cone at the bottom, fit its short flue section inside the top of the already installed 150mm diameter flue pipe. Ensure the 3 brackets extended below the flashing cone fit "outside" the outer casing slip section. Drill through the pre-punched hole in all 3 brackets into the outer casing slip and secure with rivets.

10. Taking the "removable section of the ECO cowl" assembled in section 8 above, position it over the top of the stainless steel flue pipe extension, and slide it down fully. This removable section does not require riveting and therefore enables easy removal for future flue cleaning.

Minimum Heights Metro Flue Systems (ALL) In compliance with AS/NZS2918:2001.

The Metro ECO Flue Systems comply with AS/NZS2918:2001 and its 4.6 metre height requirement (4.6 metre minimum from the top of the floor protector to the top of the flue pipe). However as external structures and the proximity of other buildings will differ for every installation, some situations will require additional flue height to comply with the standard.

Refer to Diagrams 3 and 4 below. (All measurements in mm)

Note: AS/NZS2918:2001 Section 4, details flue system installation requirements in full.

Diagram 3

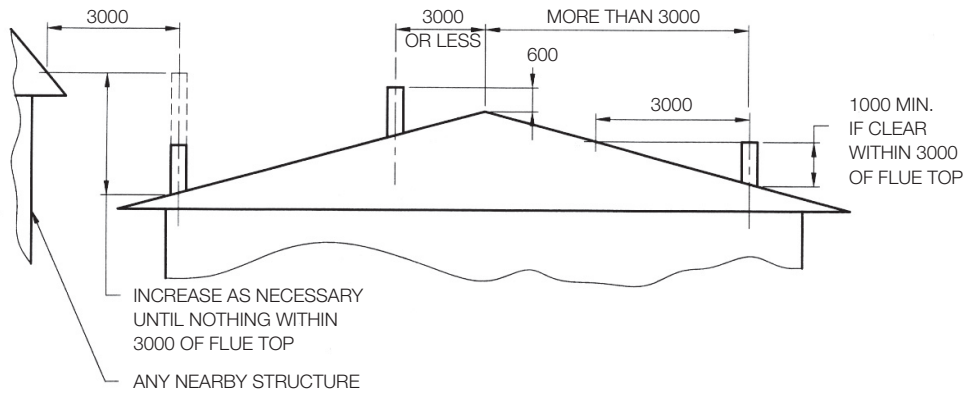

Diagram 4

